

SCALARWORKS®

S H O O T E R D R I V E N®

LEAP/11

OWNER'S MANUAL



Questions?

[EMAIL SUPPORT](#)

ASSEMBLY

01.

Dry fit optic to mount to ensure proper alignment and fit.



ASSEMBLY

02.

Insert screws while applying minimal pressure to avoid cross-threading.

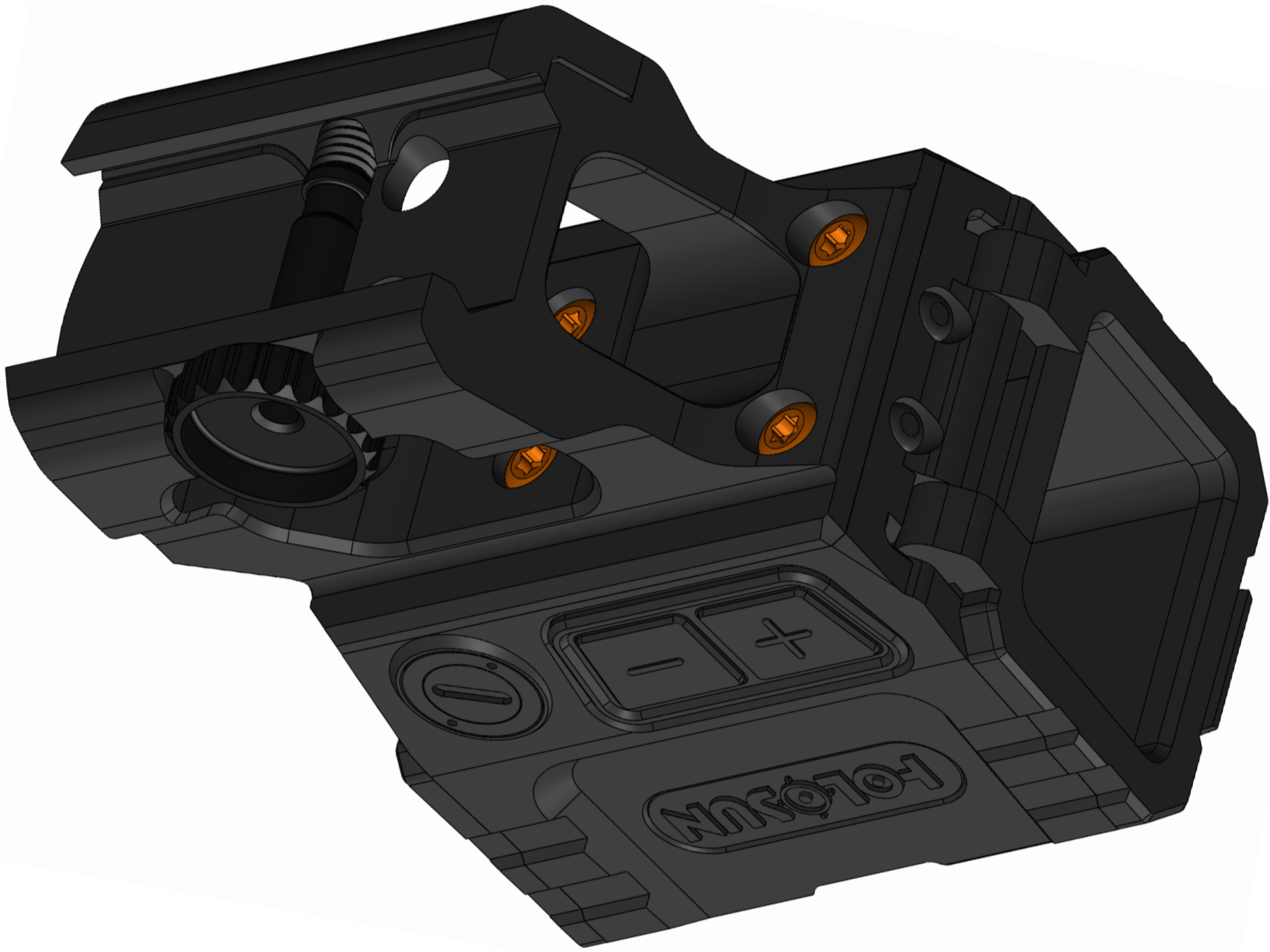

03.

Progressively tighten each screw in an X-pattern while firmly pressing driver bit into T10 socket

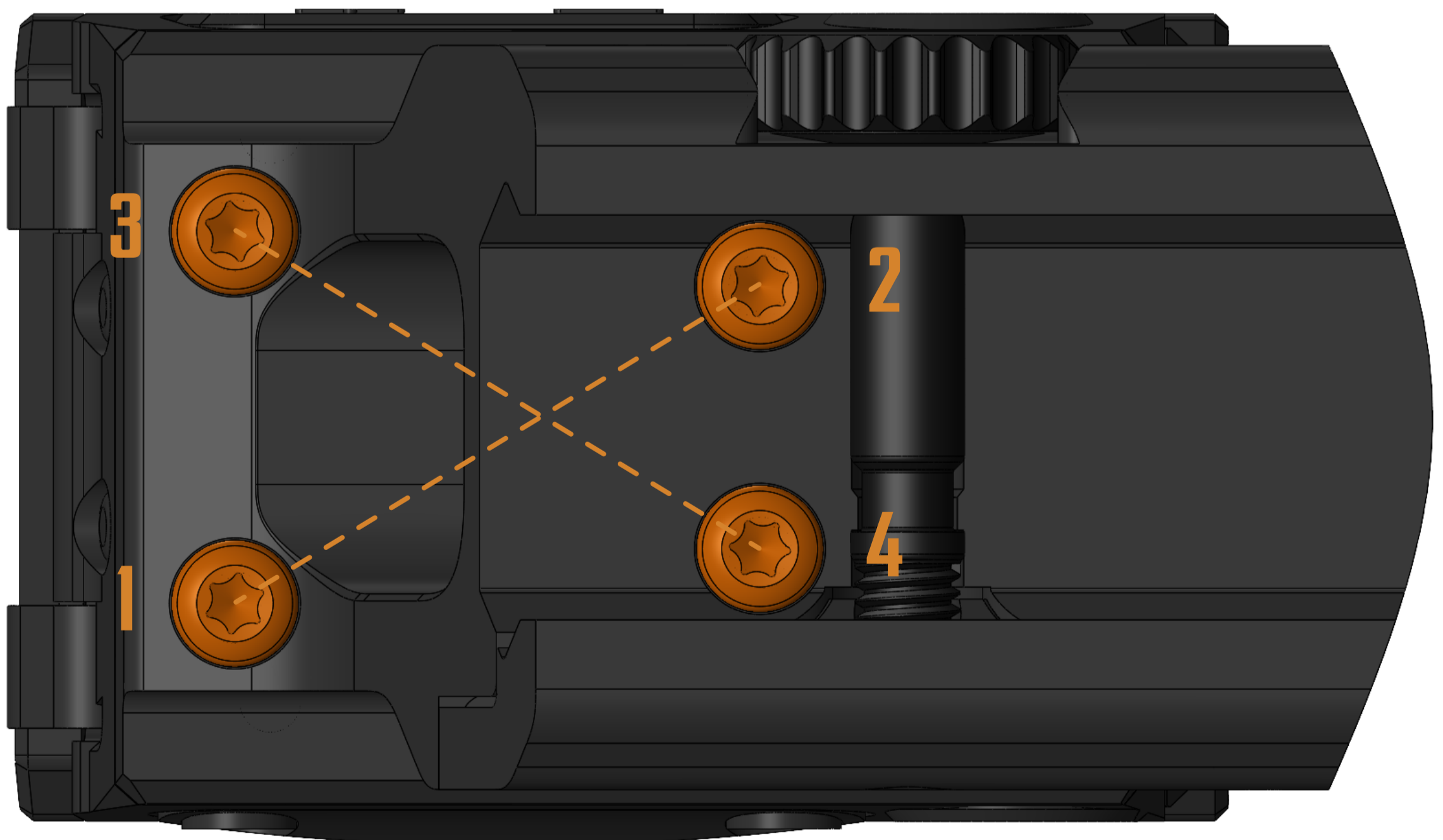

 10 INCH-LBS MAX

INSTALLATION



UNLOAD & MAKE WEAPON SAFE

01.

Open clamp no further than internal stops allow to prevent clamp from wedging itself open.

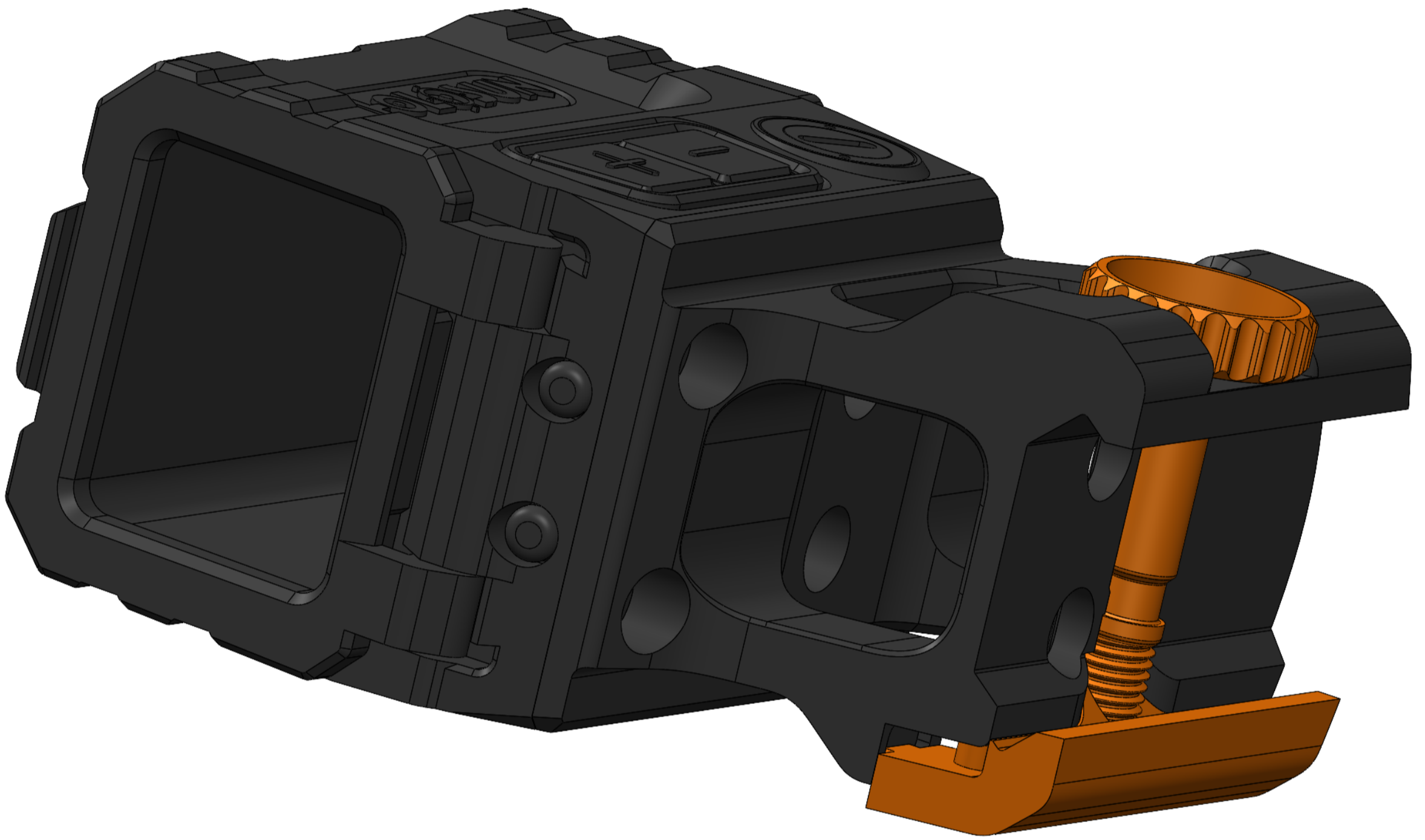

02.

Hook Leap mount onto rail from ClickDrive Side and rock onto rail.

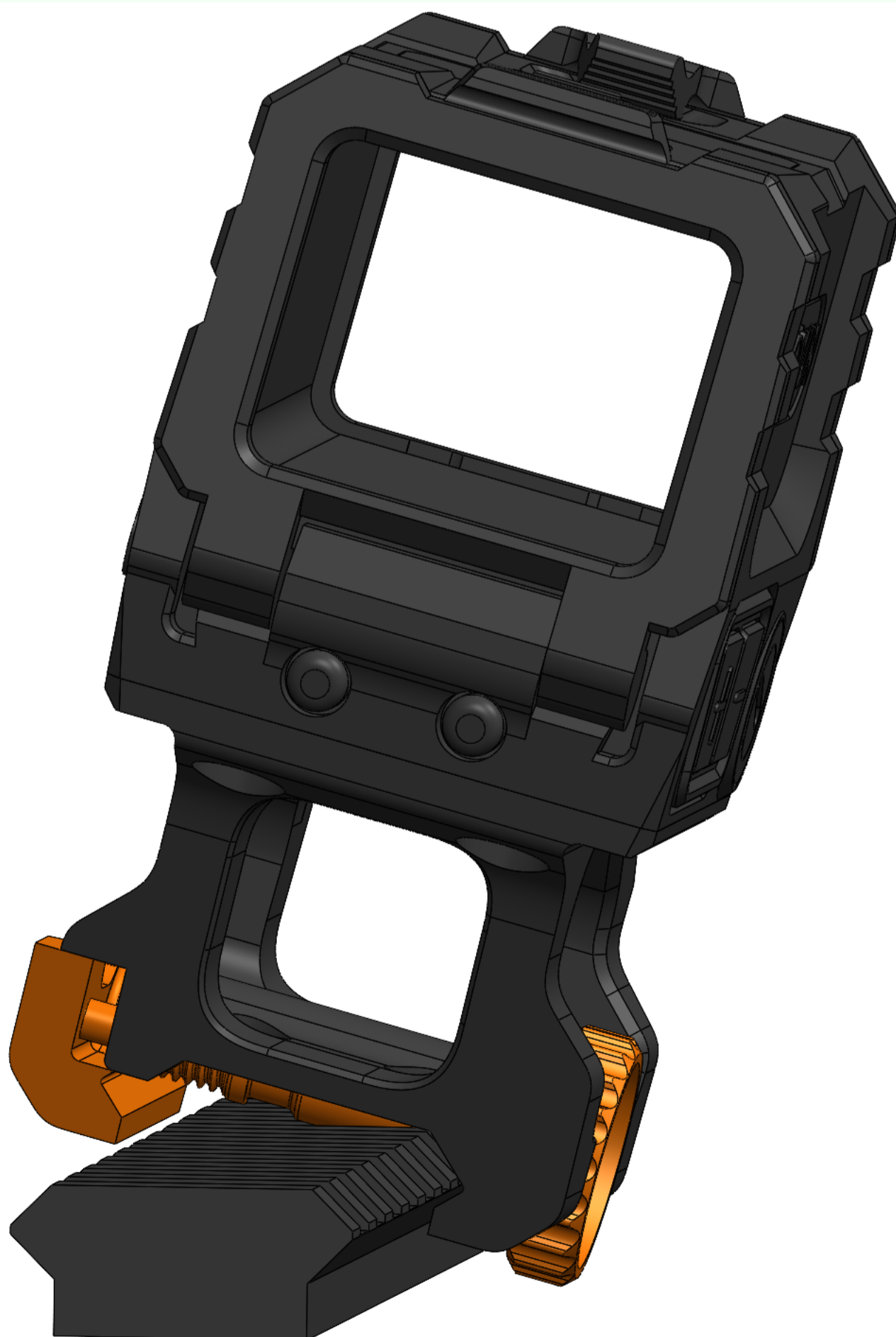

INSTALLATION



UNLOAD & MAKE WEAPON SAFE

03.

Close clamp by turning ClickDrive wheel clockwise as tightly as you can (Do not use tools).



PRO TIP

USE YOUR RIGHT HAND TO TIGHTEN AND LEFT HAND TO LOOSEN